

On Closed-loop Fault Diagnosis of Complex Mechatronic Systems

Koen Classens¹, W.P.M.H. (Maurice) Heemels¹ and Tom Oomen¹

¹Dept. of Mechanical Engineering, Eindhoven University of Technology, The Netherlands

{K.H.J.Classens, W.P.M.H.Heemels, T.A.E.Oomen}@tue.nl

1 Background

The economic value of production equipment in the high-precision industry is to a large extent determined by its productivity. It is essential to minimize downtime caused by malfunction and the associated unscheduled maintenance. To this end, digital-twin-assisted fault diagnosis systems are crucial, exploiting cheap operational data and its physics-based structure to isolate the root-cause.

2 Problem

Many fault diagnosis systems are based on parametric first principle models of the open-loop system. For instance, based on parametric models, nullspace-based fault detection and isolation (FDI) methods enable fault diagnosis for large-scale multi-input multi-output (MIMO) systems [1]. In sharp contrast, for precision mechatronics, first principle modeling is ineffective compared to data-driven modeling, which is fast, accurate, and inexpensive [2]. In addition, precision mechatronics operate in closed loop, which is often claimed not to affect the FDI system design. Given the importance for these high-precision mechatronic systems, the aim of this abstract is to develop a closed-loop and closed-loop dynamic modeling view of fault diagnosis.

3 Approach

For FDI, data-driven modeling and closed-loop interconnections are investigated. For this purpose, the consequences of interacting submodules and closed-loop operators are examined and its effect on identification and residual generator design is evaluated through a numerical analysis and experimental case study.

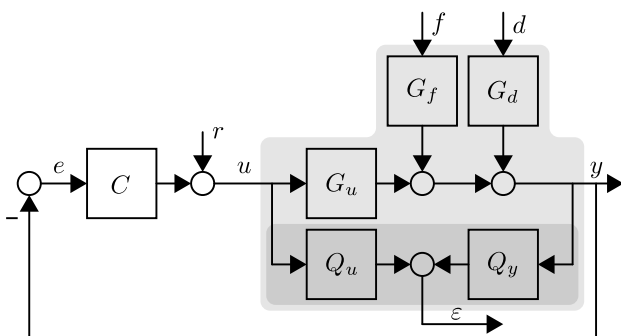

Figure 1: Closed-loop configuration for fault detection by means of the residual signal ε . The residual generator, $Q(s)$ (■), and the open-loop problem (□) are indicated.

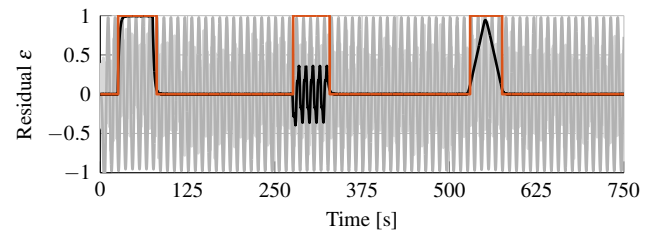

Figure 2: Comparison between normalized effective residual (—) with fault flag (—), and residual signals based on classical design techniques (—), (—).

4 Results

By means of an experimental setup, exhibiting flexible behavior similar to next-generation positioning systems, it is shown that neglecting interaction between closed-loop controlled submodules results in a severely compromised fault diagnosis system [3]. A solution is proposed in which submodules are identified and used as basis for the fault diagnosis system.

5 Outlook

The presented approach addresses ambiguity in fault detection for closed-loop systems since the operation of MIMO systems in closed-loop configuration has major implications for FDI and related system identification. Further details are communicated in [4]. The developed procedure shows that the framework for fault detection, in the form of a digital twin, can serve as the basis to maximize productivity through predictive maintenance for complex mechatronic systems.

References

- [1] A. Varga, *Solving Fault Diagnosis Problems*. Springer International Publishing, 2017.
- [2] T. Oomen, “Advanced Motion Control for Precision Mechatronics: Control, Identification, and Learning of Complex Systems,” *IEEE J. Ind. Appl. IA*, vol. 7, no. 2, 2018.
- [3] K. Classens, W. P. M. H. Heemels, and T. Oomen, “A Closed-Loop Perspective on Fault Detection for Precision Motion Control: With Application to an Overactuated System,” in *2021 ICM*, Kashiwa, Japan, 2021.
- [4] K. Classens, W. P. M. H. Heemels, and T. Oomen, “Closed-loop Aspects in MIMO Fault Diagnosis with Application to Precision Mechatronics,” in *2021 ACC*, New Orleans, USA, 2021.

This work is supported by Topconsortia voor Kennis en Innovatie (TKI), and is supported by ASML Research, Veldhoven, The Netherlands.